

INSTALLATION SHEET

INDOOR FLAGPOLES KIT “HI-TECH”

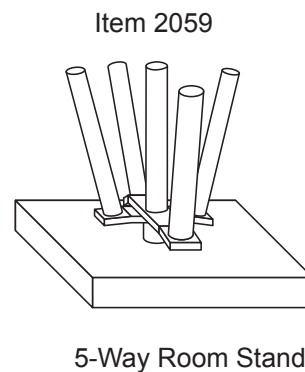
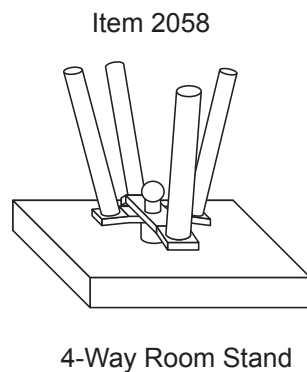
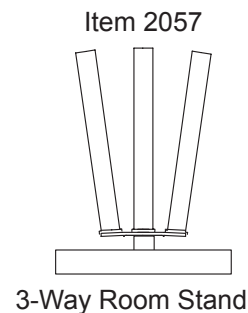
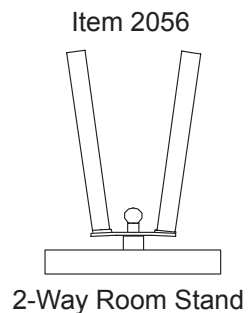
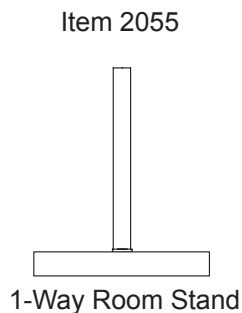

1) Installation of the base:

Insert the bolt (A) into weight (B) and then insert the base (C).

- **For the 1-way model (Item 2055)** screw the stand holder (E) directly onto the base.

- **For the 2-way model (Item 2056)** locate the base plate (D) and tighten with the small flagpole ball. Put the two stand holders (E) into the other two holes of the base plate and screw them using bolts M10x30.

- **For the 3-way model (Item 2057)** position the base plate (D) and the spacer (D') and tighten entirely with the help of the central stand holder then screw the remaining two stand holders with the supplied bolts M10x30.

- **For the 4-way model (Item 2058)** position orthogonally the two base plate (D) and the spacer (D') and tighten with the small flagpole ball then screw the four stand holders (E) with the supplied bolts M10x30.

- **For the 5-way model (Item 2059)** position orthogonally the two base plate (D) and the spacer (D') and tighten with the small flagpole ball then screw the four stand holders (E) with the supplied bolts M10x30.

2) Flagpole installation:

Screw together tube (F) and tube (G). Position the flagpole ball or the spear (H) in the base of the supplementary device maintaining the screwing direction of the pole. Tie up the flag.

3) Complete the flagpole assembly.

Insert the pre-assembled flagpole into the stand holder (E).

Ref. 1,2,3,4,5 - Way Stand	Quality Hi-Tech	Title/ Indoor Flagpole Stand		Projected by: CRESKO'S PROJECT OFFICE	File/ Indoor Flagpole Stand
INDOOR FLAGPOLE STAND HI-TECH				Checked by: Arch. Marco Scozzari	Date: 19/01/2008
Technical Sheet	Modification 0	Sheet 1/1		Approved by: Dr. Enrico Scozzari	Scale: ----

